

Perfect pocket size—fits in your bag!

Crochet

Tunisian Crochet Stitch Guide



**LEISURE
ARTS**
the art of everyday living
www.leisurearts.com

by Kim Guzman

Tunisian Crochet Stitch Guide



LEISURE ARTS, INC. • Little Rock, Arkansas

EDITORIAL STAFF

Vice President of Editorial: Susan White Sullivan
Special Projects Director: Susan Frantz Wiles
Director of E-Commerce and Prepress Services: Mark Hawkins
Creative Art Director: Katherine Laughlin
Technical Editors: Sarah J. Green and Cathy Hardy
Technical Writer: Lois J. Long
Editorial Writer: Susan McManus Johnson
Art Category Manager: Lora Puls
Graphic Artist: Becca Snider Tally
Imaging Technician: Stephanie Johnson
Prepress Technician: Janie Marie Wright
Contributing Photographer: Ken West
Contributing Photo Stylist: Sondra Daniel
Manager of E-Commerce: Robert Young

BUSINESS STAFF

President and Chief Executive Officer: Rick Barton
Vice President of Finance: Laticia Mull Dittrich
Director of Corporate Planning: Anne Martin
National Sales Director: Martha Adams
Information Technology Director: Brian Roden
Controller: Francis Caple
Vice President of Operations: Jim Dittrich
Retail Customer Service Manager: Stan Raynor
Vice President of Purchasing: Fred F. Pruss

We would like to thank Cascade Yarns for providing the yarn for this book.
Visit <http://www.cascadeyarns.com> to see all of their yarns.

We have made every effort to ensure that these instructions are accurate and complete. We cannot, however, be responsible for human error, typographical mistakes, or variations in individual work.

Copyright © 2013 by Leisure Arts, Inc., 5701 Ranch Drive, Little Rock, AR 72223-9633, www.leisurearts.com. All rights reserved. This publication is protected under federal copyright laws. Reproduction or distribution of this publication or any other Leisure Arts publication, including publications which are out of print, is prohibited unless specifically authorized. This includes, but is not limited to, any form of reproduction or distribution on or through the Internet, including posting, scanning, or e-mail transmission.

Made in USA.

Library of Congress Control Number: 2013931896

ISBN-13: 9781464707391

KIM GUZMAN



fills each day with creativity. Whether she's knitting or crocheting a new design or working on a new canning experiment with the fruit and vegetables she grows at her home in Arkansas, she fulfills a lifelong dream—endless creative ventures in a lovely country setting with her family close at hand. Her mother likes to call Kim the garden paparazzi when she rushes out to take photos of flowers, fruit, vegetables, and beautiful butterflies.

The design work that helps Kim realize this dream has won several awards, including eight “Flamies” from the Crochet Liberation Front. One of these was the 2011 award for Best Teacher. Kim has authored several pattern books, and her designs have appeared in yarn craft magazines.

Kim says, “My goal is to produce crocheted items which more closely resemble knitted garments. Even my ribbed garments are designed to specifically avoid bulkiness.”

*See more of Kim's creations at KimaneDesigns.net and CrochetKim.com. She maintains a blog called *WIPs 'N Chains* at KimGuzman.wordpress.com and is an active member of Ravelry.com.*

Learn more about Tunisian Crochet in these Leisure Arts books!

Ultimate Beginner's Guide to Tunisian Crochet • # 5599

If you like the ease of working with a crochet hook, but admire the look and feel of knitted fabric, you'll love learning Tunisian Crochet. Award-winning teacher Kim Guzman walks you through the basics and takes you through each step with clear photos and friendly instructions. Nine fresh projects, including the unique Hoodie Vest on the cover, will help you develop the skills you need.

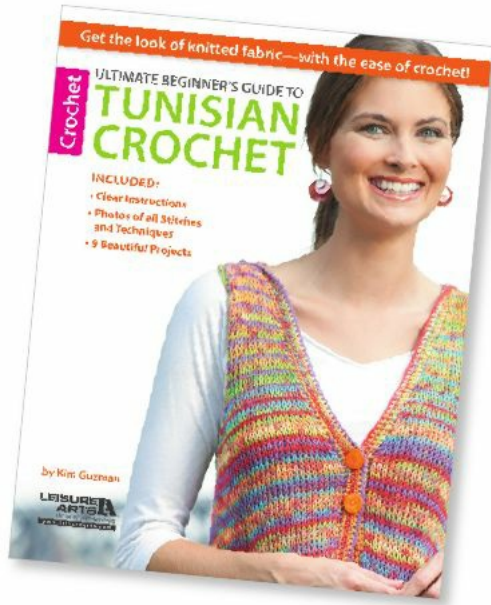

Short Row Tunisian Fashion • # 5729

In less time than you might imagine, you can make fun hats, a scarf, a lacy wrap, a feminine cardigan, and a romantic two-piece cape—all with the “fun and addictive” Short Row Tunisian Crochet technique. Kim says, “Because your rows are constantly changing, it doesn’t get monotonous and projects seem to fly off the hook in no time at all.”



Find these books at your local store or online at www.LeisureArts.com



Chapter 1

Learning Charts

An introduction to 14 fundamental stitches of Tunisian Crochet and their symbols, with full explanations of how to read their charts.

In this chapter, we introduce you to 14 stitches that are the building blocks of Tunisian Crochet stitch patterns. Spend a little time getting familiar with each stitch, and then you'll be ready to progress into more complex patterns in the chapters that follow. You'll find the master symbol list and guide to reading charts indispensable.

Experiment

Try the stitch pattern you chose with different yarns and different hooks for the right look you want for your project.

Create

Create your own one-of-a-kind project.

Each chapter introduces you to symbols used in charted Tunisian crochet. Once you have learned the basic stitches, you can increase your knowledge in the Typical, Color, and Lace Stitches.

As an aid to learning, the Scarf on [page](#) , has complete written instructions plus a chart showing each stitch pattern used. This project is a perfect example of experimenting with different yarns and hooks. Although the stitch pattern used is from the Color chapter, the project is worked in only one color with a larger hook, giving it a more lacy look.

Each row of Tunisian crochet is worked in two parts; a forward pass and a return pass. Whether you are right- or left-handed, the forward pass will always be read from right to left and the return pass will be read from left to right. As you will not be turning your work, the chart is always read as it is printed.

The final row of Tunisian crochet project is a binding off row. This is not shown on the charts. The type of binding off you desire, or even whether you choose not to include a binding off row, is a personal choice. For the most part, most stitch patterns can be bound off in slip stitch, inserting your hook as for Tunisian Simple Stitch (tss) or in the same predominant stitch of your stitch pattern. You can also bind off in single crochet, double crochet or in any stitch of your choosing.

Multiples

Multiples are the number of stitches required to work a pattern.

How to Read A Chart

- Each chart will show the beginning chains in the lower row of boxes (1). Chain the number of stitches indicated by the multiple given below the title for each stitch. For the chart below, you can chain any amount to begin.
- A Tunisian row is charted as a pair of boxes with the row number or F for the Foundation Row in the right hand column (2).
- The lower set of boxes for a row is the Forward Pass (3).
- The upper set of boxes for a row is the Return Pass (4).
- The stitch repeat, if applicable, is indicated on the bottom edge of the charts; for example [Stitch 7](#), page 18.
- The Key contains all the stitches used and the hook insertions needed for a stitch if applicable. A complete Master List of the symbols used are on [pages 10](#) and [11](#)

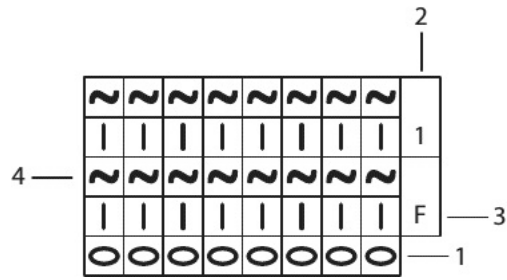

KEY

 Chain (ch)

 Tunisian Simple Stitch (tss)

 Normal Closing

Master List

Typical Hook Insertions

 Tunisian Simple Stitch (tss)

 Tunisian Reverse Stitch (trs)

 Tunisian Knit Stitch (tk)

 Tunisian Knit Stitch Purl

 Tunisian Purl Stitch (tps)

 Tunisian Full Stitch (tfs)

 Top of Closing Cluster

 Top Horizontal Bar



2 stitches worked together

 2 Tunisian Double Stitches worked together

 2 stitches worked together Purled

 3 stitches worked together

 3 stitches worked together as for tss, then [ch 1](#)

Closing (Return Pass)

 Normal Closing

 Close 3 stitches together

 Chain 1, close 3 stitches together, chain 1

Other Stitches

 Chain (ch)

 Yarn Over (YO)

 Tunisian Extended Stitch (tes)

 Tunisian Double Stitch (tds)

 Tunisian Bobble Stitch (tbs)

 Tunisian 3-Double Stitch Bobble Stitch, with ch for a tes

 Tunisian Puff Stitch

 Tunisian Crossed Stitch, worked across 2 stitches

 Tunisian Double Crossed Stitch (2 tds crossed across 3 sts)

 Tunisian Twisted Stitch worked as for tss or tks

 Tunisian Twisted Stitch Purl

 Tunisian Extended Stitch (tes) worked as for tfs

 Tunisian Double Stitch (tds) worked as for tfs

 Pull loop through as indicated, yarn over, pull loop through as indicated (3 loops on hook)

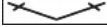
 2 Tunisian Double Stitches worked in same position (the number of tds indicates the number of stitches to work in the same position)

 Tunisian Slipped Stitch



























When left blank, there is a skipped stitch

Keys with the charts will indicate which hook insertion to use to create the stitches.

STITCH 1

Can be worked on any number of chs.



									
									1
									
									F
									

KEY

 Chain (ch)

1 Tunisian Simple Stitch (tss)

2 Normal Closing

STITCH GUIDE

TUNISIAN SIMPLE STITCH (abbreviated tss)

Insert hook from right to left under next vertical bar (Fig. 2, page 92), YO and pull up a loop.

Foundation Row: Pull up a loop in horizontal bar of second ch from hook and in each ch across, close (Figs. 1a-c, page 91).

Row 1: Skip first vertical bar, work tss across, close.

Repeat Row 1 for pattern.

STITCH 2

Can be worked on any number of chs.

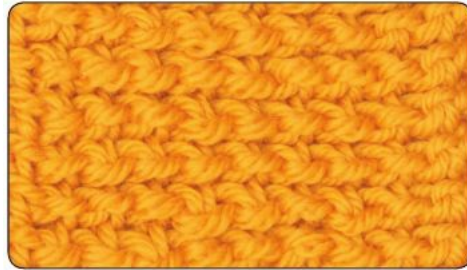

2	2	2	2	2	2	2	2	
1	1	1	1	1	1	1	1	1
2	2	2	2	2	2	2	2	
1	1	1	1	1	1	1	1	F
0	0	0	0	0	0	0	0	

KEY

0 Chain (ch)

1 Tunisian Simple Stitch (tss)

1 Tunisian Reverse Stitch (trs)

2 Normal Closing

STITCH GUIDE

TUNISIAN REVERSE STITCH (abbreviated trs)

With hook at back of work, insert hook from right to left under next back vertical bar (Fig. 5, page 92), YO and pull up a loop.

Foundation Row: Pull up a loop in horizontal bar of second ch from hook and in each ch across, close (Figs. 1a-c, page 91).

Row 1: Skip first vertical bar, work trs across, close.

Repeat Row 1 for pattern.

STITCH 3

Can be worked on any number of chs.



~	~	~	~	~	~	~	~		
⊖	⊖	⊖	⊖	⊖	⊖	⊖	⊖		1
~	~	~	~	~	~	~	~		
									F
○	○	○	○	○	○	○	○		

KEY

○ Chain (ch)

| Tunisian Simple Stitch (tss)

⊖ Tunisian Knit Stitch (tks)

~ Normal Closing

STITCH GUIDE

TUNISIAN KNIT STITCH (abbreviated tks)

Insert hook from front to back between front and back vertical bars of next st (Fig. 3, page 92), YO and pull up a loop.

Foundation Row: Pull up a loop in horizontal bar of second ch from hook and in each ch across, close. (Figs. 1a-c, page 91).

Row 1: Skip first vertical bar, work tks across, close.

Repeat Row 1 for pattern.

STITCH 4

Can be worked on any number of chs.



~	~	~	~	~	~	~	~	
-	-	-	-	-	-	-	-	1
~	~	~	~	~	~	~	~	
								F
o	o	o	o	o	o	o	o	

KEY

 Chain (ch)

 Tunisian Simple Stitch (tss)

 Tunisian Purl Stitch (tps)

 Normal Closing

STITCH GUIDE

TUNISIAN PURL STITCH (abbreviated tps)

With yarn in front of work, insert hook from right to left under next vertical bar ([Fig. 6](#), page 93), YO and pull up a loop.

Foundation Row: Pull up a loop in horizontal bar of second ch from hook and in each ch across, close ([Figs. 1a-c](#), page 91).

Row 1: Skip the first vertical bar, work tps across, close.

Repeat Row 1 for pattern.

STITCH 5

Can be worked on any number of chs.



~	~	~	~	~	~	~	~	
Q	Q	Q	Q	Q	Q	Q		1
~	~	~	~	~	~	~	~	
								F
O	O	O	O	O	O	O	O	

KEY

 Chain (ch)

 Tunisian Simple Stitch (tss)

 Tunisian Twisted Stitch worked as for tks

 Normal Closing

STITCH GUIDE

TUNISIAN TWISTED KNIT STITCH

Using the hook tip, pull the front next vertical bar over until you see the back vertical bar (Fig. 7, page 93). Insert hook between vertical bars as for Tunisian Knit Stitch, YO and pull up a loop.

Foundation Row: Pull up a loop in horizontal bar of second ch from hook and in each ch across, close (Figs. 1a-c, page 91).

Row 1: Skip the first vertical bar, work Tunisian Twisted Knit Stitch across, close.
Repeat Row 1 for pattern.

STITCH 6

Can be worked on any number of chs.

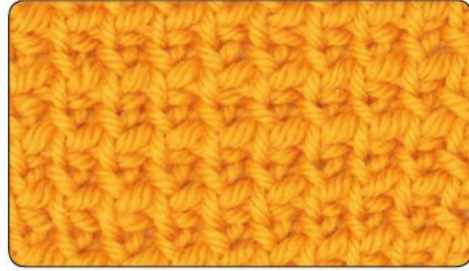

~	~	~	~	~	~	~	~	
Q	Q	Q	Q	Q	Q	Q		1
~	~	~	~	~	~	~	~	
								F
O	O	O	O	O	O	O	O	

KEY

 Chain (ch)

 Tunisian Simple Stitch (tss)

 Tunisian Twisted Simple Stitch worked as for tss

 Normal Closing

STITCH GUIDE

TUNISIAN TWISTED SIMPLE STITCH

Using the hook tip, grasp the next front vertical bar of next st, twist the hook down and around, forming a twist (Fig. 8, page 93), YO and pull up a loop.

Foundation Row: Pull up a loop in horizontal bar of second ch from hook and in each ch across, close (Figs. 1a-c, page 91).

Row 1: Skip the first vertical bar, work Tunisian Twisted Simple Stitch across, close.
Repeat Row 1 for pattern.

STITCH 7

Chain a multiple of 2 chs.



~	~	~	~	~	~	~	~	
⊖	⊖	⊖	⊖	⊖	⊖	⊖		2
~	~	~	~	~	~	~	~	
⊖	⊖	⊖	⊖	⊖	⊖	⊖		1
~	~	~	~	~	~	~	~	
								F
⊖	⊖	⊖	⊖	⊖	⊖	⊖	⊖	
								Repeat

KEY

⊖ Chain (ch)

| Tunisian Simple Stitch (tss)

⊖ Tunisian Knit Stitch (tk)

⊖ Tunisian Knit Stitch Purl

~ Normal Closing

STITCH GUIDE

TUNISIAN KNIT STITCH (abbreviated tks)

Insert hook from front to back between front and back vertical bars of next st (Fig. 3, page 92), YO and pull up a loop.

TUNISIAN KNIT STITCH PURLED (abbreviated tks purled)

With yarn in front of work, insert hook from front to back between front and back vertical bars (Fig. 4, page 92), YO and pull up a loop.

Foundation Row: Pull up a loop in horizontal bar of second ch from hook and in each ch across, close (Figs. 1a-c, page 91).

Row 1: Skip first vertical bar, work tks, (work tks purled, work tks) across, close.

Row 2: Skip first vertical bar, work tks purled, (work tks, work tks purled) across, close.

Repeat Rows 1 and 2 for pattern.

STITCH 8

Chain a multiple of 3 + 2 chs.



~	~	~	~	~	~	~	~	~	~	
	⊕	⊕	⊕	⊕	⊕	⊕	⊕	⊕		2
~	⊕	~	⊕	~	⊕	~	⊕	~	⊕	
⊕	⊕	⊕	⊕	⊕	⊕	⊕	⊕	⊕	⊕	1
~	~	~	~	~	~	~	~	~	~	
										F
○	○	○	○	○	○	○	○	○	○	
										Repeat

KEY

○ Chain (ch)

⊏ Tunisian Simple Stitch (tss)

⊕ Tunisian Extended Stitch (tes) worked as for tks

⊕ Top Horizontal Bar

⊕ Top of Closing Cluster

⊕ worked across 3 sts as follows: ch 1, close 3 sts together, ch 1

~ Normal Closing

STITCH GUIDE

TUNISIAN EXTENDED STITCH (abbreviated tes)

Insert hook from front to back between front and back vertical bars of next st, [YO (Fig. 9, page 93) and pull up a loop, YO and draw through one loop on hook (ch 1 made)].

Foundation Row: Pull up a loop in horizontal bar of second ch from hook and in each ch across, close (Figs. 1a-c, page 91).

Row 1:

Step A (Forward Pass): Skip first vertical bar, ch 1 (counts as first tes), work tes across.

Step B (Return Pass): ★ Ch 2, YO and draw through 4 loops on hook (Cluster made); repeat from ★ across to last 2 loops on hook, ch 1, YO and draw through last 2 loops on hook.

Row 2: Skip first vertical bar, pull up a loop in next horizontal bar of ch and in each horizontal bar across (Fig. 14,

page 95), close.

Repeat Rows 1 and 2 for pattern.

STITCH 9

Can be worked on any number of chs.



~	~	~	~	~	~	~	~	
								2
~	~	~	~	~	~	~	~	
†	†	†	†	†	†	†	⊙	1
~	~	~	~	~	~	~	~	
								F
○	○	○	○	○	○	○	○	

KEY

○ Chain (ch)

|| Tunisian Simple Stitch (tss)

⊙ Tunisian Extended Stitch (tes)

† Tunisian Double Stitch (tds) worked as for tss

~ Normal Closing

STITCH GUIDE

TUNISIAN DOUBLE STITCH (abbreviated tds)

YO, insert hook from right to left under next vertical bar, YO and pull up a loop, YO and draw through 2 loops on hook (Figs. 10a & b, page 94).

Foundation Row: Pull up a loop in horizontal bar of second ch from hook and in each ch across, close (Figs. 1a-c, page 91).

Row 1: Ch 1 (counts as first tes), skip first vertical bar, work tds across, close.

Row 2: Skip first vertical bar, work tss across, close.

Repeat Rows 1 and 2 for pattern.

STITCH 10

Chain a multiple of 4 + 5 chs.



~	~	~	~	~	~	~	~	~	~	~	~	~	~		4
o	o	o	o	o	o	o	o	o	o	o	o	o	o		3
~	~	~	~	~	~	~	~	~	~	~	~	~	~	~	3
o	o	o	o	o	o	o	o	o	o	o	o	o	o		2
~	~	~	~	~	~	~	~	~	~	~	~	~	~	~	1
o	o	o	o	o	o	o	o	o	o	o	o	o	o		1
~	~	~	~	~	~	~	~	~	~	~	~	~	~	~	F
o	o	o	o	o	o	o	o	o	o	o	o	o	o	o	
Repeat															

KEY

o Chain (ch)

| Tunisian Simple Stitch (tss)

o Tunisian Knit Stitch (tks)

o Tunisian Bobble Stitch (tbs) worked as for tks and tes

~ Normal Closing

STITCH GUIDE

TUNISIAN DOUBLE STITCH (abbreviated tds)

YO, insert hook from front to back, between front and back vertical bars of next st, YO and pull up a loop, YO and draw through 2 loops on hook (Figs. 10a & b, page 94).

TUNISIAN BOBBLE STITCH (abbreviated tbs)

Work 3 tds in st indicated, YO and draw through 3 loops on hook (Figs. 11a & b, page 94).

Foundation Row: Pull up a loop in horizontal bar of second ch from hook and in each ch across, close (Figs. 1a-c, page 91).

Row 1: Skip first vertical bar, work tks, work tbs in next st, ★ work 3 tks, work tbs in next st; repeat from ★ across to last 2 sts, work 2 tks, close.

Row 2: Skip first vertical bar, work tks across, close.

Row 3: Skip first vertical bar, (work 3 tks, work tbs in next st) across to last 4 sts, work 4 tks, close.

Row 4: Skip first vertical bar, work tks across, close.

Repeat Rows 1-4 for pattern.

STITCH 11

Chain a multiple of 2 + 3 chs.

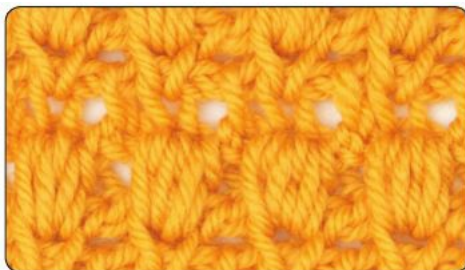

STITCH GUIDE

TUNISIAN KNIT STITCH (abbreviated tks)

Insert hook from front to back, between front and back vertical bars of next st (Fig. 3, page 92), YO and pull up a loop.

Foundation Row: Pull up a loop in horizontal bar of second ch from hook and in each ch across, close (Figs. 1a-c, page 91).

Row 1: Skip first vertical bar, ★ YO, skip next stitch, work tks; repeat from ★ across, close.

Row 2:

Step A (Forward Pass): Skip first 2 vertical bars, (YO, work tks) 3 times in next st (Puff St begun), ★ skip next st, (YO, work tks) 3 times in next st (Puff St begun); repeat from ★ across to last 2 sts, skip next st, work tks.

Step B (Return Pass): Ch 2, ★ YO and draw through 7 loops on hook (Puff St closed), ch 1; repeat from ★ across to last 2 loops on hook, YO and draw through last 2 loops on hook.

Row 3: Skip first vertical bar, ★ pull up a loop in horizontal bar of next st and in each st across to last st, work tss, close.

Repeat Rows 1-3 for pattern.

~	~	~	~	~	~	~	~	~	~	~	
	⊕	⊕	⊕	⊕	⊕	⊕	⊕	⊕	⊕		3
~	○	~	○	~	○	~	○	~	○	~	
○		⊖		⊖		⊖		⊖			2
~	~	~	~	~	~	~	~	~	~	~	
○	○	○	○	○	○	○	○	○	○		1
~	~	~	~	~	~	~	~	~	~	~	
											F
○	○	○	○	○	○	○	○	○	○	○	
Repeat											

KEY	
⊖ Chain (ch)	⊕ Top of Closing Cluster
Tunisian Simple Stitch (tss)	□ Skipped stitch (intentionally left blank)
○ Yarn over (as used for a stitch) (YO)	⊖ = ○ + ○ + ○ + ○ + ○ + ○ Tunisian Puff Stitch worked as for tks; worked in same stitch, creates 6 loops on hook
○ Tunisian Knit Stitch (tks)	~ Normal Closing
⊕ Top Horizontal Bar	

STITCH 12

Chain a multiple of 4 + 5 chs.



STITCH GUIDE

TUNISIAN PURL STITCH (abbreviated tps)

With yarn in front of work, insert hook from right to left under next vertical bar (Fig. 6, page 93), YO and pull up a loop.

TUNISIAN CROSSED STITCH (uses 2 sts)

Skip next vertical bar, insert hook from right to left under next vertical bar, YO and pull up a loop, insert hook from right to left under skipped vertical bar, YO and pull up a loop (Figs. 12a & b, page 94).

Foundation Row: Pull up a loop in horizontal bar of second ch from hook and in each ch across, close (Figs. 1a-c, page 91).

Row 1: Skip first vertical bar, (work 2 tps, work Tunisian Crossed St) across to last 4 sts, work 4 tps, close.

Row 2: Skip first vertical bar, work tps, work Tunisian Crossed St, (work 2 tps, work Tunisian Crossed St) across to last st, work tps, close.

Row 3: Skip first vertical bar, (work Tunisian Crossed St, work 2 tps) across, close.

Row 4: Skip first vertical bar, work 3 tps, work Tunisian Crossed St, (work 2 tps, work Tunisian Crossed St) across to last 3 sts, work 3 tps, close.

Repeat Rows 1-4 for pattern.

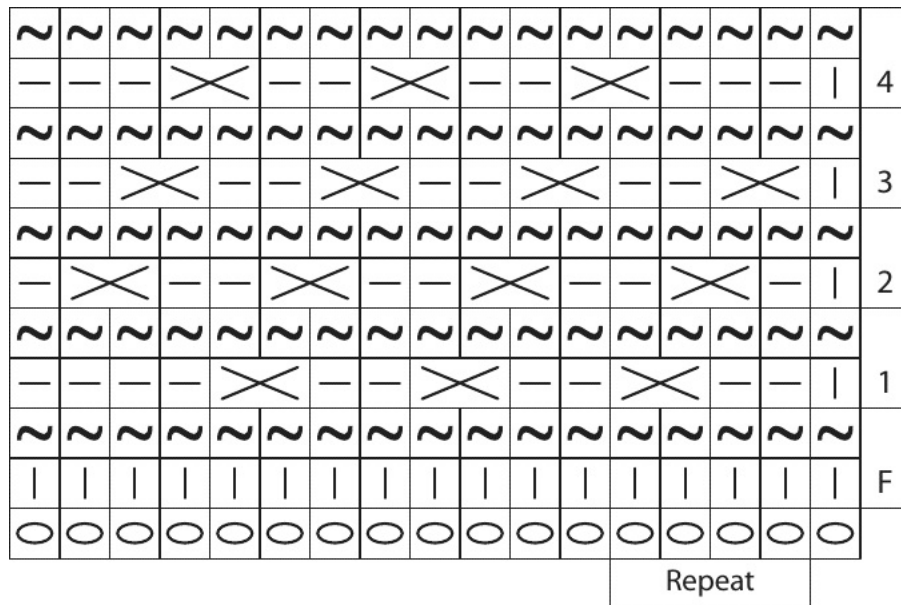

KEY

 Chain (ch)

 Tunisian Simple Stitch (tss)

 Tunisian Purl Stitch (tps)

 Tunisian Crossed Stitch worked as for tss

 Normal Closing

STITCH 13

Chain a multiple of 3 + 2 chs.

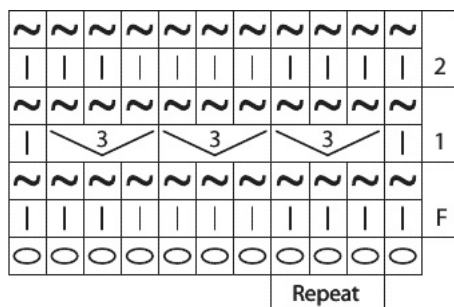

KEY

○ Chain (ch)

| Tunisian Simple Stitch (tss)

3 = | + ○ + | worked in same stitch

~ Normal Closing

Foundation Row: Pull up a loop in horizontal bar of second ch from hook and in each ch across, close (Figs. 1a-c, page 91).

Row 1: Skip first 2 vertical bars, insert hook under next vertical bar, YO and pull up a loop, YO, insert hook under same vertical bar, YO and pull up a loop (3 sts made from one), ★ skip next 2 vertical bars, insert hook under next vertical bar, YO and pull up a loop, YO, insert hook under same vertical bar, YO and pull up a loop (3 sts made from one); repeat from ★ across to last 2 sts, skip next vertical bar, work tss; close.

Row 2: Skip first vertical bar, work tss across, close.

Repeat Rows 1 and 2 for pattern.

STITCH 14

Chain a multiple of 2 chs.

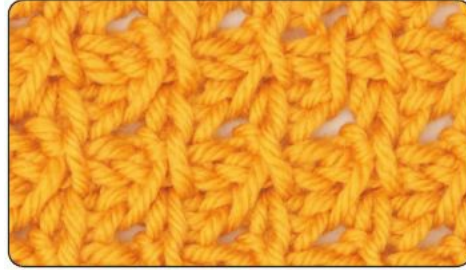

~	~	~	~	~	~	~	~	~	2
—		—		—		—			
~	~	~	~	~	~	~	~	~	1
	⊕	↗	⊕	↗	⊕	↗			
~	~	~	~	~	~	~	~	~	F
○	○	○	○	○	○	○	○	○	Repeat

KEY

○ Chain (ch)

| Tunisian Simple Stitch (tss)

— Tunisian Purl Stitch (tps)

⊕ = ↗ + ⊕ tss2tog worked as for Tunisian Full Stitch (tfs)

~ Normal Closing

STITCH GUIDE

TUNISIAN FULL STITCH (abbreviated tfs)

Insert hook from front to back under horizontal bar between two sts (Fig. 14, page 95), YO and pull up a loop.

TUNISIAN SIMPLE STITCH 2 TOGETHER (abbreviated tss2tog)

Insert hook from right to left under next 2 vertical bars, YO and pull up a loop (Figs. 17a& b, page 96).

TUNISIAN PURL STITCH (abbreviated tps)

With yarn in front of work, insert hook from right to left under next vertical bar (Fig. 6, page 93), YO and pull up a loop.

Foundation Row: Pull up a loop in horizontal bar of second ch from hook and in each ch across, close (Figs. 1a-c, page 91).

Row 1: Skip first vertical bar, (work tss2tog, work tfs) across to last st, work tss, close.

Row 2: Skip first vertical bar, work tps, (work tss, work tps) across, close.
Repeat Rows 1 and 2 for pattern.



Chapter 2

Typical Stitches

Here you go beyond the basic stitches, with 17 richly textured pattern stitches presented in the typical format for charted Tunisian Crochet.

When you are ready for more variety, this assortment of pattern stitches uses twists, purls, double stitches, and other tricks to challenge you. Choose an easy pattern that repeats just a few rows, or branch out with a more-involved one that offers a hint of hearts or a checkerboard look. You'll return to this collection time after time to add excitement to scarves, afghans, and other items.

STITCH 15

Chain a multiple of 2 chs.
Repeat Rows 1 and 2 for pattern.



~	~	~	~	~	~	~	~	
○	○	⌋	○	⌋	○	⌋		2
~	~	~	~	~	~	~	~	
○	⌋	○	⌋	○	⌋	○		1
~	~	~	~	~	~	~	~	
								F
○	○	○	○	○	○	○	○	
Repeat								

KEY

○ Chain (ch)

| Tunisian Simple Stitch (tss)

 Tunisian Reverse Stitch (trs)

































 Tunisian Knit Stitch (tk)

 Normal Closing

STITCH 16

Chain a multiple of 2 chs.
Repeat Rows 1 and 2 for pattern.



								
								2
								
								1
								
								F
								
								Repeat

KEY

 Chain (ch)

 Tunisian Simple Stitch (tss)

 Tunisian Purl Stitch (tps)

 Normal Closing

STITCH 17

Chain a multiple of 5 + 4 chs.
Repeat Row 1 for pattern.

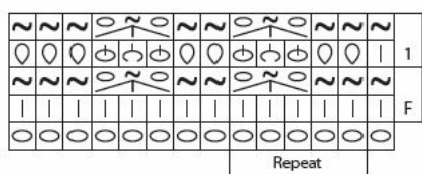

KEY

0 Chain (ch)

| Tunisian Simple Stitch (tss)

0 Tunisian Knit Stitch (tk)

~ worked across 3 sts as follows: **ch 1**, close 3 sts together, **ch 1**

⊕ Top Horizontal Bar

⊕ Top of Closing Cluster

~ Normal Closing

STITCH 18

Chain a multiple of 4 chs.
Repeat Row 1 for pattern.





~	~	~	~	~	~	~	~	~	~	~	~	
	Q	Q	-	-	Q	Q	-	-	Q	Q		1
~	~	~	~	~	~	~	~	~	~	~	~	
												F
o	o	o	o	o	o	o	o	o	o	o	o	
Repeat												

KEY

 Chain (ch)

 Tunisian Simple Stitch (tss)

 Tunisian Purl Stitch (tps)

 Tunisian Twisted Stitch worked as for tks

 Normal Closing

STITCH 19

Chain a multiple of 4 chs.
Repeat Rows 1-4 for pattern.



~	~	~	~	~	~	~	~	~	~	~	~	~	~	~	~	
○	○	○	—	—	○	○	—	—	○	○	—	—	○	○		4
~	~	~	~	~	~	~	~	~	~	~	~	~	~	~	~	
○	○	○	—	—	○	○	—	—	○	○	—	—	○	○		3
~	~	~	~	~	~	~	~	~	~	~	~	~	~	~	~	
○	—	—	○	○	—	—	○	○	—	—	○	○	—	—		2
~	~	~	~	~	~	~	~	~	~	~	~	~	~	~	~	
○	—	—	○	○	—	—	○	○	—	—	○	○	—	—		1
~	~	~	~	~	~	~	~	~	~	~	~	~	~	~	~	
																F
○	○	○	○	○	○	○	○	○	○	○	○	○	○	○	○	
														Repeat		

KEY

○ Chain (ch)

| Tunisian Simple Stitch (tss)

○ Tunisian Knit Stitch (tks)

— Tunisian Purl Stitch (tps)

~ Normal Closing

STITCH 20

Chain a multiple of 2 + 1 ch.
Repeat Rows 1 and 2 for pattern.



~	~	~	~	~	~	~	~	~	~	~	~	~	2
	⊖	—	⊖	—	⊖	—	⊖	—	⊖	—	⊖		
~	~	~	~	~	~	~	~	~	~	~	~	~	1
⊖	—	⊖	—	⊖	—	⊖	—	⊖	—	⊖	—	⊖	
~	~	~	~	~	~	~	~	~	~	~	~	~	F
○	○	○	○	○	○	○	○	○	○	○	○	○	
												Repeat	

KEY

○ Chain (ch)

| Tunisian Simple Stitch (tss)

— Tunisian Purl Stitch (tps)

⊖ Tunisian Extended Stitch (tes) worked as for tks

~ Normal Closing

STITCH 21

Chain a multiple of 2 chs.
Repeat Rows 1-4 for pattern.



~	~	~	~	~	~	~	~	~	~	~	~	~	~	
		⊕		⊕		⊕		⊕		⊕		⊕		4
~	~	~	~	~	~	~	~	~	~	~	~	~	~	
	↘	⊙	↘	⊙	↘	⊙	↘	⊙	↘	⊙	↘	⊙		3
~	~	~	~	~	~	~	~	~	~	~	~	~	~	
⌞	⌞	⌞	⌞	⌞	⌞	⌞	⌞	⌞	⌞	⌞	⌞	⌞	⌞	2
~	~	~	~	~	~	~	~	~	~	~	~	~	~	
⌞	⌞	⌞	⌞	⌞	⌞	⌞	⌞	⌞	⌞	⌞	⌞	⌞	⌞	1
~	~	~	~	~	~	~	~	~	~	~	~	~	~	
														F
○	○	○	○	○	○	○	○	○	○	○	○	○	○	
													Repeat	

KEY

○ Chain (ch)

⌞ Tunisian Simple Stitch (tss)

⌞ Tunisian Reverse Stitch (trs)

⊕ Top Horizontal Bar

↘ = ○ + ↘ Yarn over, tss2tog

~ Normal Closing

STITCH 22

Chain a multiple of 6 + 5 chs.
Repeat Rows 1-4 for pattern.



~	~	~	~	~	~	~	~	~	~	~	~	~	~	~	~	~	4
				⊕	⊕	⊕				⊕	⊕	⊕					
~	~	~	~	⌞	⌞	⌞	~	~	~	⌞	⌞	⌞	~	~	~	~	3
	Ⓚ	Ⓚ	Ⓚ	Ⓚ	Ⓚ	Ⓚ	Ⓚ	Ⓚ	Ⓚ	Ⓚ	Ⓚ	Ⓚ	Ⓚ	Ⓚ	Ⓚ		
~	~	~	~	~	~	~	~	~	~	~	~	~	~	~	~	~	2
	⊕	⊕	⊕				⊕	⊕	⊕				⊕	⊕	⊕		
~	⌞	⌞	⌞	~	~	~	⌞	⌞	⌞	~	~	~	⌞	⌞	⌞	~	1
	Ⓚ	Ⓚ	Ⓚ	Ⓚ	Ⓚ	Ⓚ	Ⓚ	Ⓚ	Ⓚ	Ⓚ	Ⓚ	Ⓚ	Ⓚ	Ⓚ	Ⓚ		
~	~	~	~	~	~	~	~	~	~	~	~	~	~	~	~	~	F
○	○	○	○	○	○	○	○	○	○	○	○	○	○	○	○	○	

Repeat

KEY

○ Chain (ch)	Ⓚ Tunisian Twisted Stitch worked as for tss
Tunisian Simple Stitch (tss)	⌞ worked across 3 sts as follows: ch 1, close 3 sts together, ch 1
⊕ Top Horizontal Bar	~ Normal Closing
⊕ Top of Closing Cluster	

STITCH 23

Chain a multiple of 3 + 2 chs.
Repeat Row 1 for pattern.



~	~	~	~	~	~	~	~	~	~	~	~	~	~	~	~	~	~	~	~	~
	↓	⊗	⊗	↓	⊗	⊗	↓	⊗	⊗	↓	⊗	⊗	↓	⊗	⊗					1
~	~	~	~	~	~	~	~	~	~	~	~	~	~	~	~	~	~	~	~	~
																				F
○	○	○	○	○	○	○	○	○	○	○	○	○	○	○	○	○	○	○	○	○
																	Repeat			

KEY

○ Chain (ch)

| Tunisian Simple Stitch (tss)

↓ Tunisian Reverse Stitch (trs)

⊗ = ⊗ + ○ with yarn in front, tss2tog (wrapped), Yarn over (YO)

~ Normal Closing

STITCH 24

Chain a multiple of 10 + 9 chs.
Repeat Rows 1-10 for pattern.

~ Normal Closing

STITCH 25

Can be worked on any number of chs.
Repeat Rows 1 and 2 for pattern.

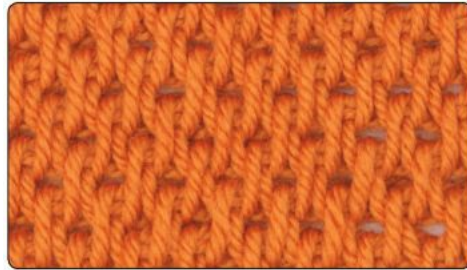

~	~	~	~	~	~	
○	Φ	Φ	Φ	Φ	—	2
~	~	~	~	~	~	
○	Φ	Φ	Φ	Φ	—	1
~	~	~	~	~	~	
—	—	—	—	—	—	F
○	○	○	○	○	○	

KEY

○ Chain (ch)

⌊ Tunisian Simple Stitch (tss)

Φ Tunisian Full Stitch (tfs)

○ Tunisian Knit Stitch (tks)

~ Normal Closing

Note: Since the tfs is worked between stitches, the chart is offset.

STITCH 26

Chain a multiple of 12 + 5 chs.
Repeat Rows 3-16 for pattern.

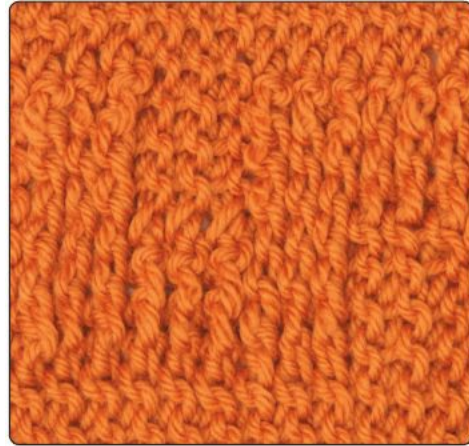

KEY

 Chain (ch)

 Tunisian Simple Stitch (tss)

 Tunisian Reverse Stitch (trs)

 Tunisian Knit Stitch (tks)

 Normal Closing

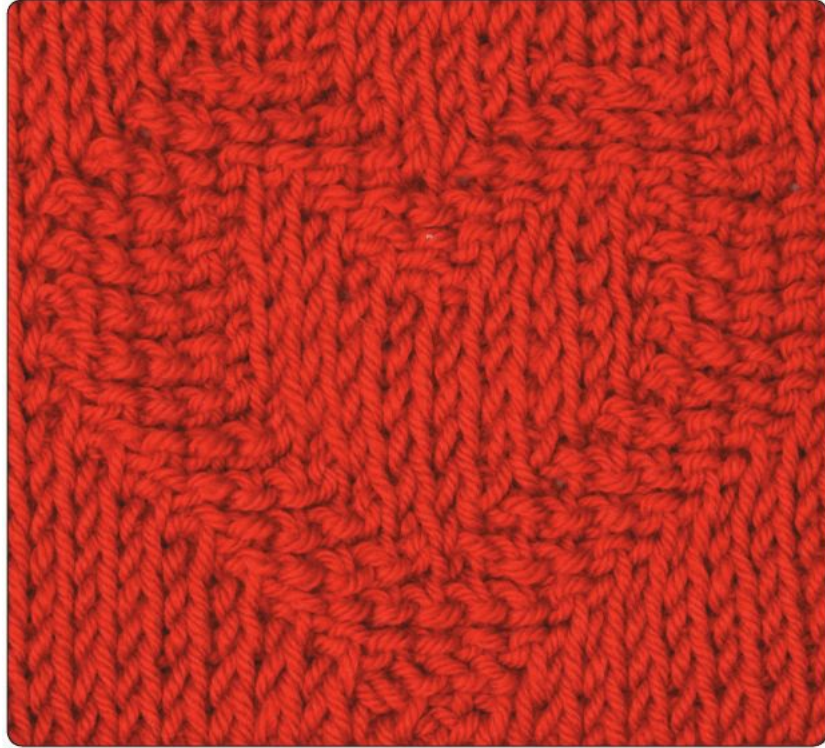

KEY

 Chain (ch)

 Tunisian Simple Stitch (tss)

 Tunisian Reverse Stitch (trs)

 Tunisian Knit Stitch (tks)

 Normal Closing

KEY

○ Chain (ch)

▮ Tunisian Simple Stitch (tss)

⊢ Tunisian Double Stitch (tds) worked as for tss

▮ Tunisian Purl Stitch (tps)

⌞ Normal Closing

STITCH 29

Chain a multiple of 8 + 6 chs.
Repeat Rows 1-8 for pattern.



⌞	⌞	⌞	⌞	⌞	⌞	⌞	⌞	⌞	⌞	⌞	⌞	⌞	⌞	⌞	⌞	⌞	⌞	⌞	⌞	⌞	8		
▮	▮	▮	▮	▮	▮	⊢	⊢	▮	▮	▮	▮	▮	▮	⊢	⊢	▮	▮	▮	▮	▮	▮	8	
⌞	⌞	⌞	⌞	⌞	⌞	⌞	⌞	⌞	⌞	⌞	⌞	⌞	⌞	⌞	⌞	⌞	⌞	⌞	⌞	⌞	⌞	7	
▮	▮	▮	⊢	⊢	▮	▮	▮	▮	▮	▮	▮	▮	▮	⊢	⊢	▮	▮	▮	▮	⊢	▮	7	
⌞	⌞	⌞	⌞	⌞	⌞	⌞	⌞	⌞	⌞	⌞	⌞	⌞	⌞	⌞	⌞	⌞	⌞	⌞	⌞	⌞	⌞	6	
▮	▮	⊢	⊢	▮	▮	▮	▮	▮	▮	⊢	⊢	▮	▮	▮	▮	⊢	⊢	▮	▮	▮	▮	6	
⌞	⌞	⌞	⌞	⌞	⌞	⌞	⌞	⌞	⌞	⌞	⌞	⌞	⌞	⌞	⌞	⌞	⌞	⌞	⌞	⌞	⌞	5	
▮	▮	⊢	▮	▮	▮	▮	▮	▮	▮	⊢	⊢	▮	▮	▮	▮	⊢	⊢	▮	▮	▮	▮	5	
⌞	⌞	⌞	⌞	⌞	⌞	⌞	⌞	⌞	⌞	⌞	⌞	⌞	⌞	⌞	⌞	⌞	⌞	⌞	⌞	⌞	⌞	4	
▮	▮	⊢	▮	▮	▮	▮	▮	▮	▮	⊢	⊢	▮	▮	▮	▮	⊢	⊢	▮	▮	▮	▮	4	
⌞	⌞	⌞	⌞	⌞	⌞	⌞	⌞	⌞	⌞	⌞	⌞	⌞	⌞	⌞	⌞	⌞	⌞	⌞	⌞	⌞	⌞	3	
▮	▮	⊢	▮	▮	▮	▮	▮	▮	▮	⊢	⊢	▮	▮	▮	▮	⊢	⊢	▮	▮	▮	▮	3	
⌞	⌞	⌞	⌞	⌞	⌞	⌞	⌞	⌞	⌞	⌞	⌞	⌞	⌞	⌞	⌞	⌞	⌞	⌞	⌞	⌞	⌞	2	
▮	▮	▮	▮	▮	▮	⊢	⊢	▮	▮	▮	▮	▮	▮	⊢	⊢	▮	▮	▮	▮	▮	▮	2	
⌞	⌞	⌞	⌞	⌞	⌞	⌞	⌞	⌞	⌞	⌞	⌞	⌞	⌞	⌞	⌞	⌞	⌞	⌞	⌞	⌞	⌞	1	
▮	▮	▮	▮	▮	▮	⊢	⊢	▮	▮	▮	▮	▮	▮	⊢	⊢	▮	▮	▮	▮	▮	▮	1	
○	○	○	○	○	○	○	○	○	○	○	○	○	○	○	○	○	○	○	○	○	○	F	
○	○	○	○	○	○	○	○	○	○	○	○	○	○	○	○	○	○	○	○	○	○	○	

Repeat

KEY	
○ Chain (ch)	⊗ Tunisian Cross Stitch worked as for tss
⌊ Tunisian Simple Stitch (tss)	~ Normal Closing
⌐ Tunisian Purl Stitch (tps)	

STITCH 30

Chain a multiple of 2 chs.
Repeat Rows 1 and 2 for pattern.

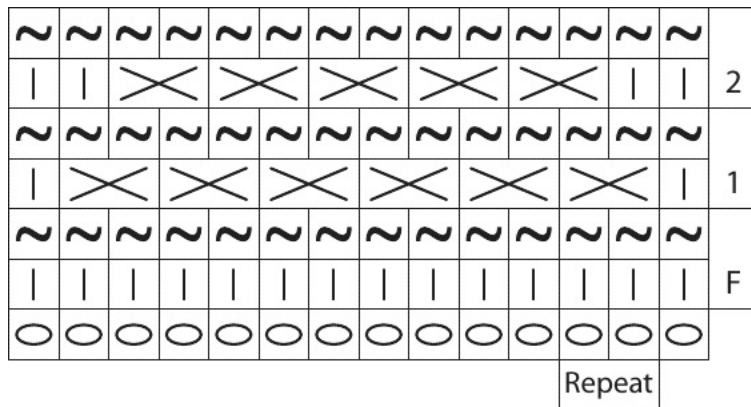
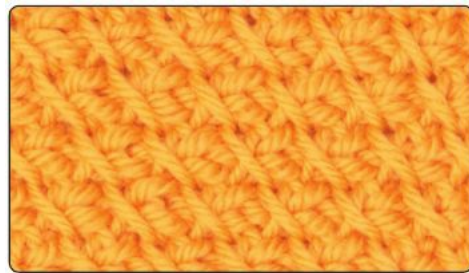

KEY	
○ Chain (ch)	
⌊ Tunisian Simple Stitch (tss)	
⊗ Tunisian Cross Stitch worked as for tss	

Normal Closing

STITCH 31

Chain a multiple of 8 + 6 chs.
Repeat Rows 1-8 for pattern.

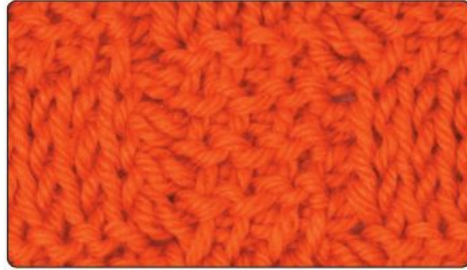

	-	-	-	-					-	-	-	-					-	-	-	-		8		
	-	-	-	-					-	-	-	-					-	-	-	-		7		
	-	-	-	-					-	-	-	-					-	-	-	-		6		
	-	-	-	-					-	-	-	-					-	-	-	-		5		
						-	-	-	-					-	-	-	-						4	
						-	-	-	-					-	-	-	-						3	
						-	-	-	-					-	-	-	-						2	
						-	-	-	-					-	-	-	-						1	
																								F
Repeat																								

KEY

Chain (ch)

Tunisian Simple Stitch (tss)

☐ Tunisian Purl Stitch (tps)

☐ Tunisian Knit Stitch (tk)

☐ Normal Closing



Chapter 3

Color Stitches

This chapter presents a collection of 12 pattern stitches that combine two or three yarn colors.

You can always count on color to add pizzazz to your crochet! Each of these 12 pattern stitches proves what a dramatic change it can make when you combine color with different stitches. Those with a shorter height create a somewhat tweedy effect, while tall or extended stitches give more definition. But don't forget that you also can work these patterns in a single color, as we did by using Stitch 40 for the Scarf on page – who would have guessed!

STITCH 32

Chain a multiple of 6 + 11 chs.
 Repeat Row 1 for pattern.
 Note: Change colors at end of row (Forward Pass) (Fig. 18b, page 96).

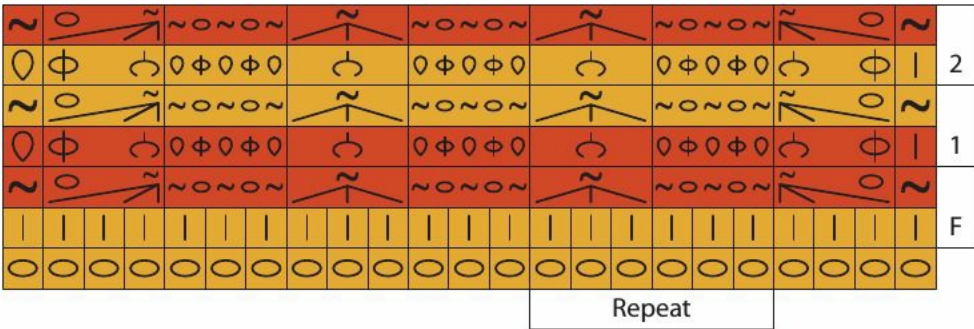

KEY

○ Chain (ch)

⊕ Tunisian Simple Stitch (tss)

○ Tunisian Knit Stitch (tk)

☉ Tunisian Full Stitch (tfs)

☪ Top of Closing Cluster

⌒ close 3 sts together

⌒ Normal Closing

STITCH 33

Chain a multiple of 2 chs.

Repeat Rows 1 and 2 for pattern.

Note: Change colors at end of row (Forward Pass) (Fig. 18b, page 96).

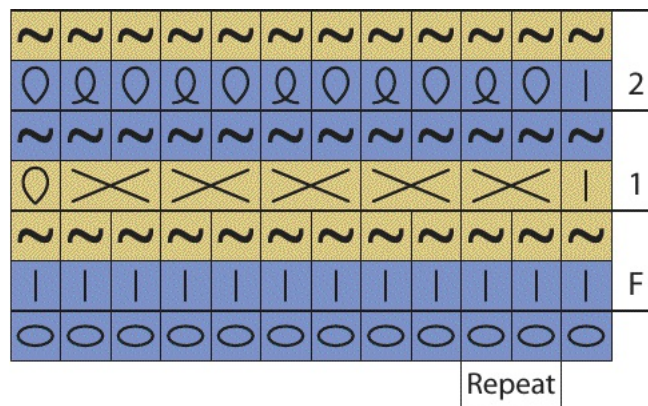

KEY

○ Chain (ch)

|| Tunisian Simple Stitch (tss)

☪ Tunisian Knit Stitch (tk)

 Tunisian Twisted Stitch worked as for tss

 Tunisian Crossed Stitch

 Normal Closing

STITCH 34

Chain a multiple of 2 chs.

Repeat Rows 1 and 2 for pattern.

Note: Change colors at end of row (Forward Pass) ([Fig. 18b](#), page 96).

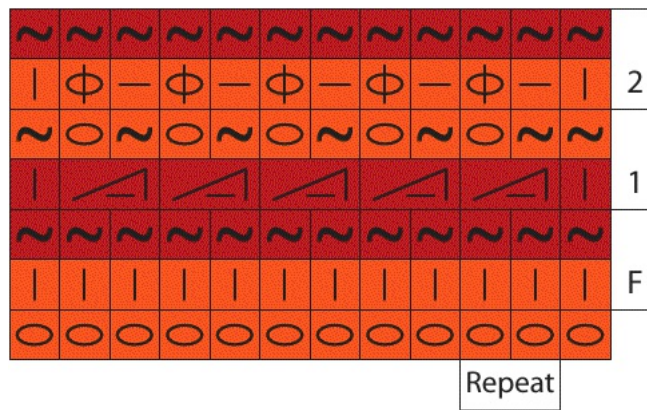

KEY

 Chain (ch)

 Tunisian Simple Stitch (tss)

 Tunisian Full Stitch (tfs)

 Tunisian Purl Stitch (tps)

 with yarn in front, tss2tog worked as for tss (wrapped)

 Normal Closing





















































































STITCH 35

Chain a multiple of 2 chs.

Repeat Rows 1 and 2 for pattern.

Note: Change colors at end of row (Forward Pass) (Fig. 18b, page 96).



												
												2
												
												1
												
												F
												

Repeat

KEY

 Chain (ch)

 Tunisian Simple Stitch (tss)

 Tunisian Twisted Stitch worked as for tks

 Normal Closing

STITCH 36

Chain a multiple of 4 + 1 ch.

Repeat Rows 1 and 2 for pattern.

Note: Change colors at beginning of row (Return Pass) (Fig. 18a, page 96).



~	~	~	~	~	~	~	~	~	~	~	~	~	~	~	~		
⊖	⊗	∇	⊗	⊗	⊗	∇	⊗	⊗	⊗	∇	⊗	⊗	⊗	∇	⊗		2
~	~	~	~	~	~	~	~	~	~	~	~	~	~	~	~		
⊖	⊗	⊗	∇	⊗	⊗	∇	⊗	⊗	∇	⊗	⊗	∇	⊗	⊗		1	
~	~	~	~	~	~	~	~	~	~	~	~	~	~	~	~		
																F	
○	○	○	○	○	○	○	○	○	○	○	○	○	○	○	○		
															Repeat		

KEY

○ Chain (ch)

| Tunisian Simple Stitch (tss)

⊗ Tunisian Twisted Stitch worked as for tks

⊖ Tunisian Knit Stitch (tks)

∇ Tunisian Slip Stitch

~ Normal Closing

STITCH 37

Chain a multiple of 2 chs.

Repeat Rows 1 and 2 for pattern.

Note: Change colors at end of row (Forward Pass) (Fig. 18b, page 96).

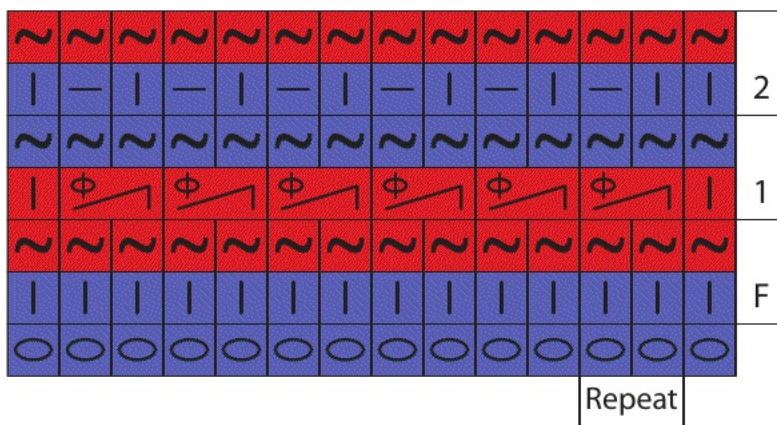

KEY

○ Chain (ch)

| Tunisian Simple Stitch (tss)

⊖ Tunisian Purl Stitch (tps)

⊕ = ⊖ + ⊕ tss2tog with a Tunisian Full Stitch (tfs)

~ Normal Closing

STITCH 38

Chain a multiple of 6 + 5 chs.

Repeat Rows 1-4 for pattern.

Note: Change colors at end of row (Forward Pass) (Fig. 18b, page 96).



~	~	~	~	⌒	⌒	⌒	~	~	~	⌒	⌒	⌒	~	~	~			4
⊙	⊔	⊙	⊔	⊙	⊙	⊙	⊔	⊙	⊔	⊙	⊙	⊙	⊔	⊙	⊔	⊙	⊔	3
~	~	~	~	~	~	~	~	~	~	~	~	~	~	~	~	~	~	2
⊙	⊙	⊔	⊙	⊙	⊔	⊙	⊔	⊙	⊔	⊙	⊙	⊙	⊔	⊙	⊔	⊙	⊔	1
~	~	~	~	⌒	⌒	⌒	~	~	~	⌒	⌒	⌒	~	~	~	~	~	F
○	○	○	○	○	○	○	○	○	○	○	○	○	○	○	○	○	○	
Repeat																		

KEY

⊙ Chain (ch)

| Tunisian Simple Stitch (tss)

⊙ Tunisian Knit Stitch (tks)

⊔ Tunisian Reverse Stitch (trs)

⊕ Top of Horizontal Bar

⊖ Top of Closing Cluster

⌒ worked across 3 sts as follows: [ch 1](#), close 3 sts together, [ch 1](#)

STITCH 39

Chain a multiple of 3 + 2 chs.

Repeat Rows 1-6 for pattern.

Note: Change colors at end of row (Forward Pass) (Fig. 18b, page 96).



~	~	~	~	~	~	~	~	~	~	~	~	~	~	~	6
o	o	o	o	o	o	o	o	o	o	o	o	o	o	o	6
~	~	~	~	~	~	~	~	~	~	~	~	~	~	~	5
└	└	└	└	└	└	└	└	└	└	└	└	└	└	└	5
~	~	~	~	~	~	~	~	~	~	~	~	~	~	~	4
o	o	o	o	o	o	o	o	o	o	o	o	o	o	o	4
~	~	~	~	~	~	~	~	~	~	~	~	~	~	~	3
└	└	└	└	└	└	└	└	└	└	└	└	└	└	└	3
~	~	~	~	~	~	~	~	~	~	~	~	~	~	~	2
—	—	o	—	—	o	—	—	o	—	—	o	—	—	o	2
~	~	o	~	~	o	~	~	o	~	~	o	~	~	o	1
+	+	+	+	+	+	+	+	+	+	+	+	+	+	+	1
~	~	~	~	~	~	~	~	~	~	~	~	~	~	~	F
—	—	—	—	—	—	—	—	—	—	—	—	—	—	—	F
o	o	o	o	o	o	o	o	o	o	o	o	o	o	o	F

Repeat

KEY

o Chain (ch)

☐ Tunisian Simple Stitch (tss)

☐ Tunisian Reverse Stitch (trs)

☐ Tunisian Extended Stitch (tes)

☐ Tunisian Knit Stitch Purl

☐ Tunisian Twisted Stitch as worked for tss

☐ Tunisian as Double Stitch (tds) worked for tss

☐ Tunisian Double Crossed Stitch skip next 2 sts, tds in next st, tds in first skipped st (center is unworked)

☐ Tunisian Full Stitch (tfs)

☐ Normal Closing

STITCH 40

Chain a multiple of 3 + 2 chs.

Repeat Rows 1 and 2 for pattern.

Note: Change colors at beginning of row (Return Pass) ([Fig. 18a](#), page 96).



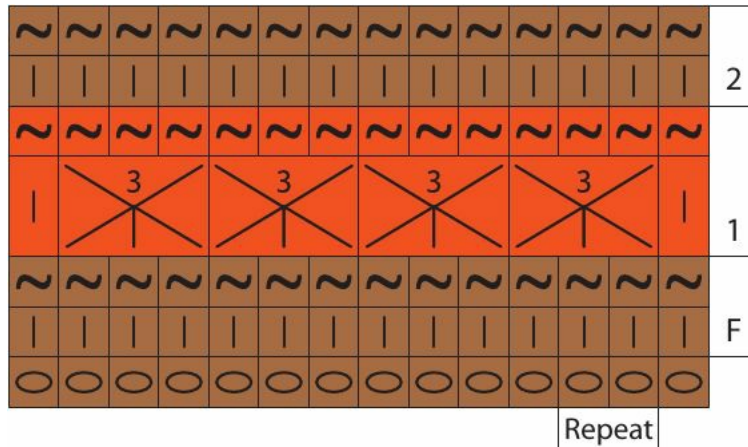

KEY

o Chain (ch)

| Tunisian Simple Stitch (tss)

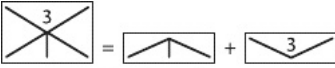
 Insert hook as for tss in next 3 sts, YO and pull up a loop, YO, insert hook in same 3 sts, YO and pull up a loop (3 loops made)

~ Normal Closing

STITCH 41

Chain a multiple of 2 chs.

Repeat Rows 1-4 for pattern.

Note: Change colors at end of row (Forward Pass) (Fig. 18b, page 96).



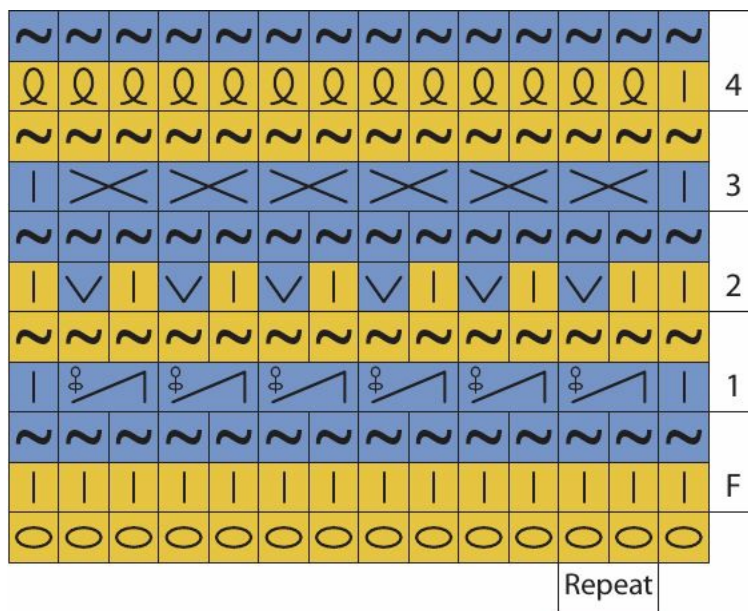

KEY

Chain (ch)

Tunisian Simple Stitch (tss)

Tunisian Twisted Stitch worked as for tss

Tunisian Cross Stitch worked as for tss

Tunisian Slip Stitch

= + tss2tog worked as for tss, then work tfs as for tes (ch after loop has been pulled up)

Normal Closing

STITCH 42

Chain a multiple of 2 chs.

Repeat Row 1 for pattern.

Note: Change colors at beginning (Return Pass) (Fig. 18a, page 96) and end of row (Forward Pass) (Fig. 18b, page 96).

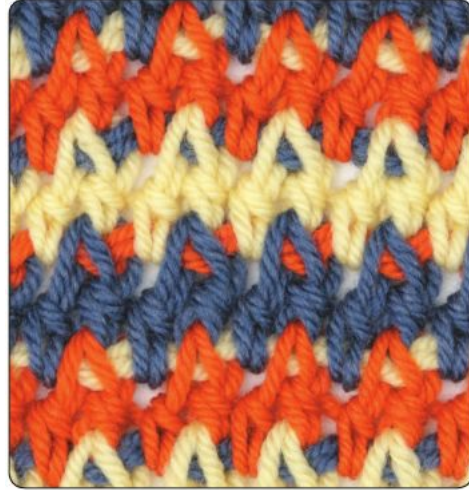

~	~	~	~	~	~	~	~	~	
†	‡	†	‡	†	‡	†	‡	⓪	1
~	~	~	~	~	~	~	~	~	
									F
⓪	⓪	⓪	⓪	⓪	⓪	⓪	⓪	⓪	
Repeat									

KEY

⓪ Chain (ch)

| Tunisian Simple Stitch (tss)

⓪ Tunisian Extended Stitch (tes)

⓪ Tunisian Full Stitch (tfs)

‡ = † + ‡ tds2tog worked as for tss then tds worked as for tfs

~ Normal Closing

STITCH 43

Chain a multiple of 2 chs.

Repeat Rows 1 and 2 for pattern.

Note: Change colors at beginning (Return Pass) (Fig. 18a, page 96) and end of row (Forward Pass) (Fig. 18b, page

96).

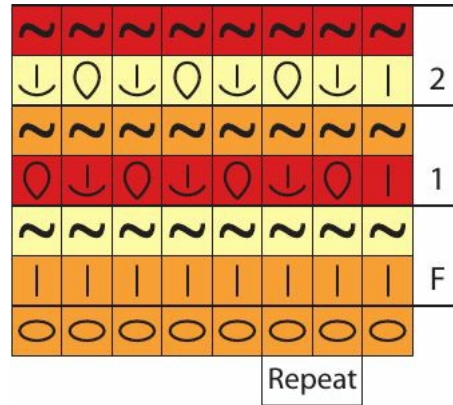

KEY

⊖ Chain (ch)

| Tunisian Simple Stitch (tss)

⊖ Tunisian Knit Stitch (tk)

⌋ Tunisian Reverse Stitch (trs)

~ Normal Closing



Chapter 4

Lace Stitches

Whether dense or airy, these 18 lace patterns let you add romantic style to your Tunisian Crochet.

Tunisian Crochet is perhaps best known as a dense fabric that makes sturdy, practical afghans. Yet it can also have a lacy quality, as these 18 pattern stitches show. You'll find shell looks, crossed stitches, extended stitches, clustered stitches, and bobbles all contributing their special features to create the lace effects, including some that resemble trees and pineapples.

STITCH 44

Chain a multiple of 3 chs.

Repeat Rows 1 and 2 for pattern.



~	~	~	~	~	~	~	~	~	~	~	~	~	~	~	~	2
	⊖	○		⊖	○		⊖	○		⊖	○		⊖	○		2
~	~	○	~	~	○	~	~	○	~	~	○	~	~	○	~	1
	⊖	⌢		⊖	⌢		⊖	⌢		⊖	⌢		⊖	⌢		1
~	~	~	~	~	~	~	~	~	~	~	~	~	~	~	~	F
																F
○	○	○	○	○	○	○	○	○	○	○	○	○	○	○	○	
Repeat																

KEY

○ Chain (ch)

| Tunisian Simple Stitch (tss)

 Tunisian Reverse Stitch (trs)

 tds2tog worked as for tss









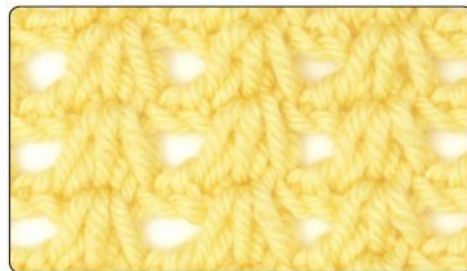









































 Yarn Over (as used for a st) (YO)

 Normal Closing

STITCH 45

Chain a multiple of 3 + 2 chs
Repeat Row 1 for pattern.



										1
										
										F
										
										
Repeat										

KEY

 Chain (ch)

 Tunisian Simple Stitch (tss)

 Top Horizontal Bar

 Top of Closing Cluster

 worked across 3 sts as follows: [ch 1](#), close 3 sts together, [ch 1](#)

 Normal Closing

STITCH 46

Chain a multiple of 3 + 2 chs.
Repeat Rows 1 and 2 for pattern.

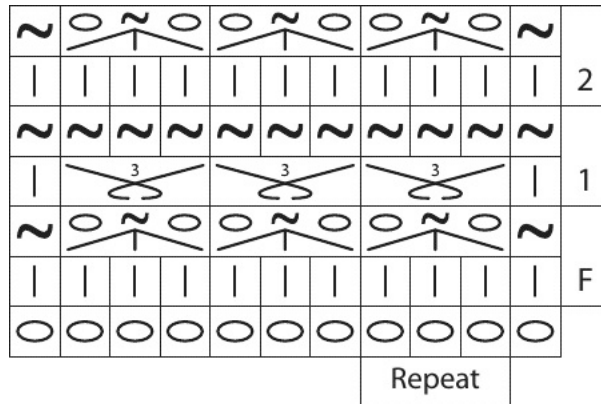





KEY

 Chain (ch)

 Tunisian Simple Stitch (tss)

 worked across 3 sts as follows: **ch 1**, close 3 sts together, **ch 1**

 =  +  +  worked together in top of Closing Cluster

 Normal Closing

STITCH 47

Chain a multiple of 3 + 2 chs.
Repeat Row 1 for pattern.

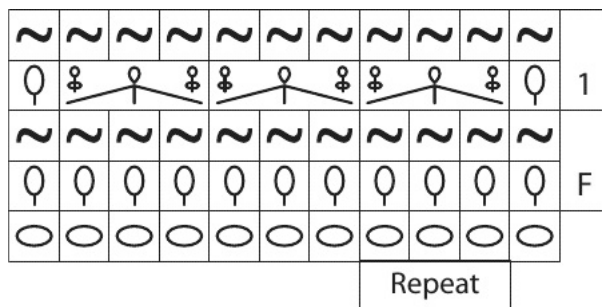

KEY

○ Chain (ch)

Q Tunisian Extended Stitch (tes)

⊕ Tunisian Extended Stitch (tes) worked as for tfs

⊕ ⊕ ⊕ = ⊕ + ⊕ + ⊕ tes worked as for tfs, 3 sts worked together as for tss, then **ch 1**, tes worked as for tfs





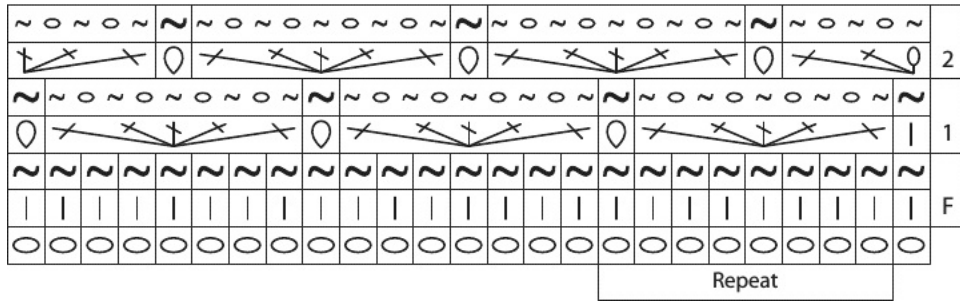

~ Normal Closing

STITCH 48

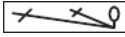
Chain a multiple of 6 + 9 chs.
Repeat Rows 1 and 2 for pattern.

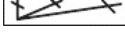

KEY

 Chain (ch)	 Ch 1, work 2 tds in first st as for tks
 Tunisian Simple Stitch (tss)	 5 tds worked as for tks in one st
 Tunisian Knit Stitch (tk)	 3 tds worked as for tks in last st
 Tunisian Double Stitch (tds) worked as for tks	 Normal Closing

STITCH 50

Chain a multiple of 6 + 2 chs.
Repeat Rows 1-12 for pattern.



KEY

 Chain (ch)

 Tunisian Simple Stitch (tss)

 Tunisian Extended Stitch (tes)

 Tunisian Double Stitch (tds) worked as for tss

 Tunisian Full Stitch (tfs)

 Tunisian Bobble Stitch

 Tunisian Double Crossed Stitch skip next 2 sts, tds in next st, tds in first skipped st (center is unworked)

 Normal Closing

KEY

○ Chain (ch)

|| Tunisian Simple Stitch (tss)

⊖ Tunisian Extended Stitch (tes)

⋈ Tunisian Double Stitch (tds)

⋈ = || + ⊖ tds2tog worked as for tss, then tes as for tss

~ Normal Closing

STITCH 52

Chain a multiple of 2 chs.
Repeat Rows 1 and 2 for pattern.



~	~	~	~	~	~	~	~	~	~	~	~	
⊖	⊖	⊖	⊖	⊖	⊖	⊖	⊖	⊖	⊖	⊖		2
~	○	~	○	~	○	~	○	~	○	~	~	
⊖	⋈	⋈	⋈	⋈	⋈	⋈	⋈	⋈	⋈			1
~	~	~	~	~	~	~	~	~	~	~	~	
												F
○	○	○	○	○	○	○	○	○	○	○	○	
												Repeat

KEY

○ Chain (ch)

⌋ Tunisian Simple Stitch (tss)

⊕ Top Horizontal Bar

↙ tss2tog worked as for tss

~ Normal Closing

STITCH 53

Chain a multiple of 4 + 1 chs.
Repeat Rows 1 and 2 for pattern.

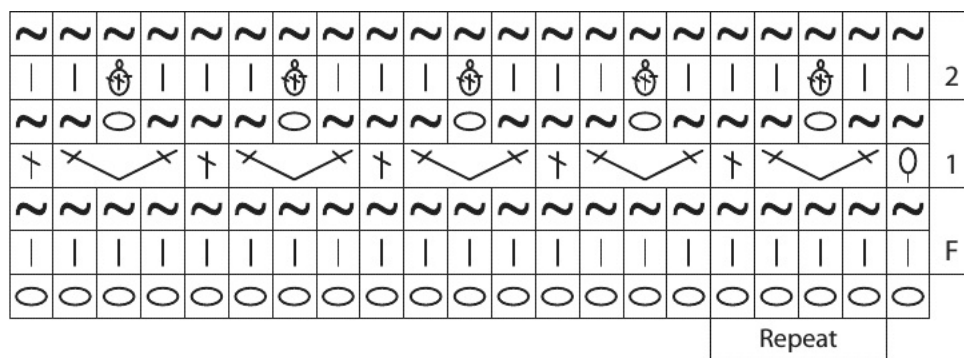



KEY

○ Chain (ch)

⌋ Tunisian Simple Stitch (tss)

⊕ Tunisian Extended Stitch (tes)

 Tunisian Double Stitch (tds) worked as for tss

 Tunisian Bobble Stitch (tbs) worked as for tfs and tes

 skip next st, 2 tds worked as for tss in next st, skip next st











































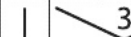
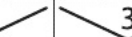
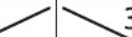
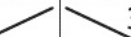











































 Tunisian Knit Stitch (tkn)

 Normal Closing

STITCH 54

Chain a multiple of 3 + 2 chs.
Repeat Rows 1-3 for pattern.









																
																3
																
														2		
																
																1
																
																F
																
Repeat																

KEY

 Chain (ch)

 Worked across 3 sts as follows: **ch 1**, close 3 sts together, **ch 1**







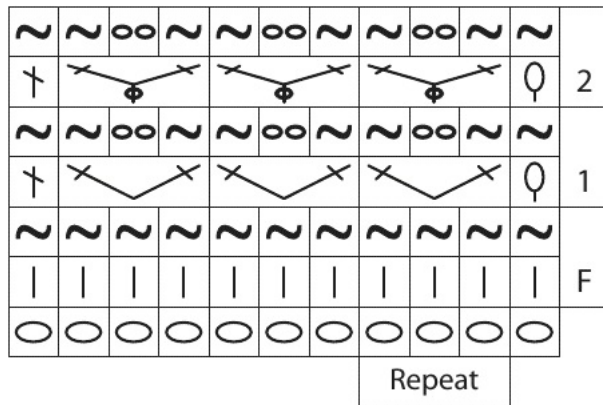

 Tunisian Simple Stitch (tss)	 =  +  +  worked in top of Closing Cluster
 Tunisian Bobble Stitch (tbs)	 Normal Closing

STITCH 55

Chain a multiple of 3 + 2 chs.
Repeat Row 2 for pattern.



KEY

 Chain (ch)	 skip next st, 2 tds worked as for tss in next st, skip next st
 Tunisian Simple Stitch (tss)	 skip next st, 2 tds worked as for tfs in same sp, skip next st
 Tunisian Extended Stitch (tes)	 Chain 2
 Tunisian Double Stitch (tds) worked as for tss	 Normal Closing

STITCH 56

Chain a multiple of 3 + 2 chs.
Repeat Rows 1 and 2 for pattern.



~	~	~	~	~	~	~	~	~	~	~	~	~	~	
		⊕			⊕			⊕			⊕			2
~	~	○	~	~	○	~	~	○	~	~	○	~	~	
†	✕		✕		✕		✕		✕		⊙		1	
~	~	~	~	~	~	~	~	~	~	~	~	~		
													F	
○	○	○	○	○	○	○	○	○	○	○	○	○		
												Repeat		

KEY

○ Chain (ch)

| Tunisian Simple Stitch (tss)

⊙ Tunisian Extended Stitch (tes)

† Tunisian Double Stitch (tds) worked as for tss

✕ Tunisian Double Crossed Stitch skip next 2 sts, tds in next st, tds in first skipped st (center is unworked)

⊕ Tunisian Full Stitch (tfs)

~ Normal Closing

STITCH 57

Chain a multiple of 2 chs.
Repeat Rows 1 and 2 for pattern.



~	~	~	~	~	~	~	~	~	~	~	~	
	Q	Q	Q	Q	Q	Q	Q	Q	Q	Q		2
~	~	~	~	~	~	~	~	~	~	~	~	
	Φ	∕	Φ	∕	Φ	∕	Φ	∕	Φ	∕		1
~	~	~	~	~	~	~	~	~	~	~	~	
												F
○	○	○	○	○	○	○	○	○	○	○	○	
											Repeat	

KEY

○ Chain (ch)

| Tunisian Simple Stitch (tss)

Q Tunisian Twisted Stitch worked as for tss

Φ = ∕ + Φ tss2tog worked as for tfs

~ Normal Closing

STITCH 58

Chain a multiple of 3 + 2 chs.
Repeat Rows 2 and 3 for pattern.



~	~	~	~	~	~	~	~	~	~	~	~	~	~	~	
⊙	⊙	⊙	⊙	⊙	⊙	⊙	⊙	⊙	⊙	⊙	⊙	⊙	⊙	⊙	3
~	○	~	○	○	~	○	○	~	○	○	~	○	~	~	
⊙	⌢			⌢			⌢			⌢			⊙	2	
~	~	~	~	~	~	~	~	~	~	~	~	~	~	~	
⊙	⊙	⊙	⊙	⊙	⊙	⊙	⊙	⊙	⊙	⊙	⊙	⊙	⊙	⊙	1
~	~	~	~	~	~	~	~	~	~	~	~	~	~	~	
															F
○	○	○	○	○	○	○	○	○	○	○	○	○	○	○	
														Repeat	

KEY

○ Chain (ch)

|| Tunisian Simple Stitch (tss)

⊙ Tunisian Extended Stitch (tes) worked as for tfs

⊙ Tunisian Extended Stitch (tes) worked as for tss









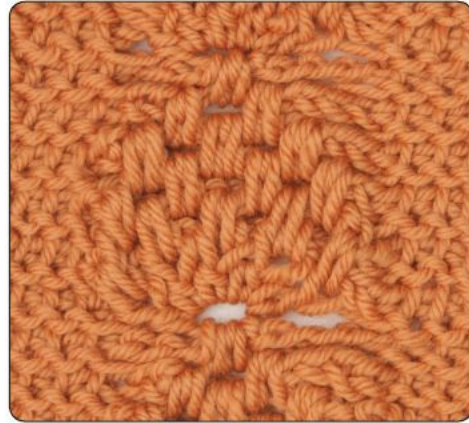





⌢ 3 sts together as for tss, then ch 1

~ Normal Closing

STITCH 59

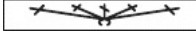
Chain a multiple of 10 + 5 chs.
Repeat Rows 6-11 for pattern.



	KEY
 Chain (ch)	 =  +  +  worked as for tks
 Tunisian Simple Stitch (tss)	 =  +  +  worked as for tfs
 Tunisian Purl Stitch (tps)	 5 tds in top of Closing Cluster
 Tunisian Double Stitch (tds) worked in top of Closing Cluster	 close 3 sts together
 Skip st	 Normal Closing

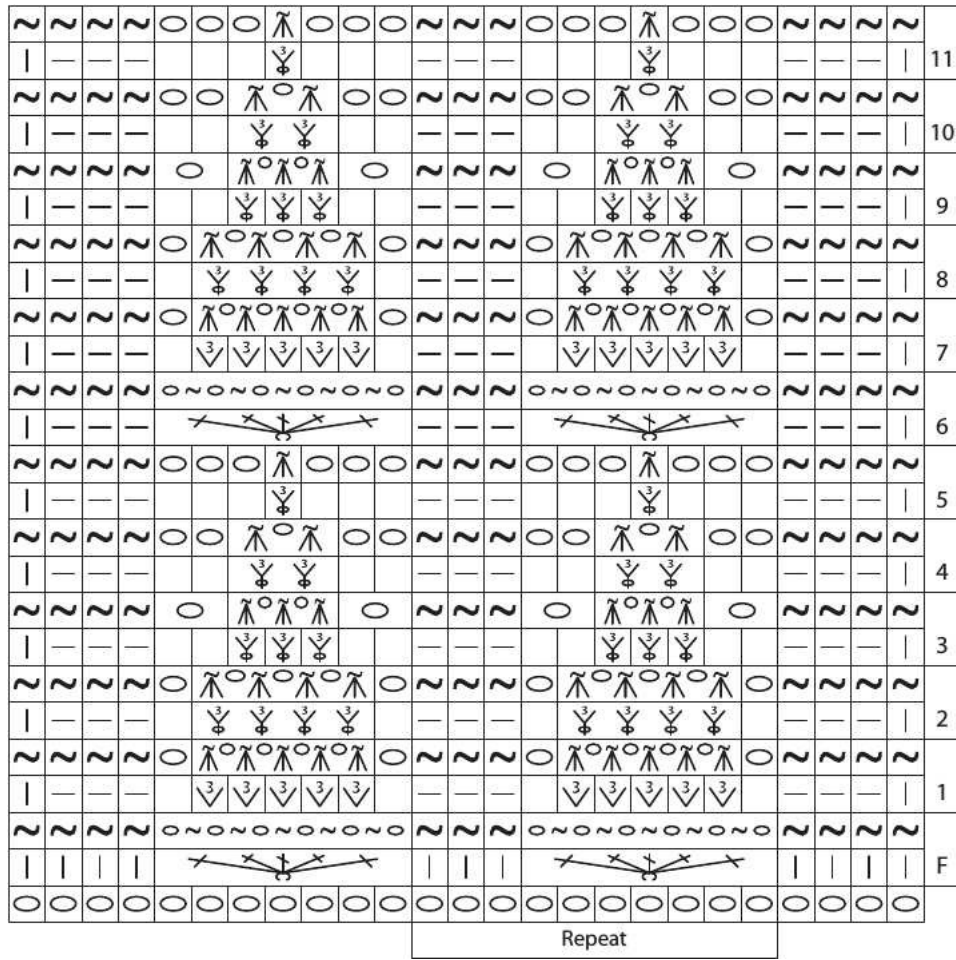















STITCH 60

Chain a multiple of 12 + 5 chs.
Repeat Rows 4-7 for pattern.



KEY

 Chain (ch)	 Top of Closing Cluster
 Tunisian Simple Stitch (tss)	 worked across 3 sts as follows: ch 1 , close 3 sts together, ch 1
 Tunisian Knit Stitch (tks)	 =  +  +  worked as for tfs
 Top Horizontal Bar	 Skip st
 Tunisian Double Stitch (tds) worked in top of Closing Cluster	 Close 3 sts together
 4 tds worked in top of Closing Cluster	 Normal Closing

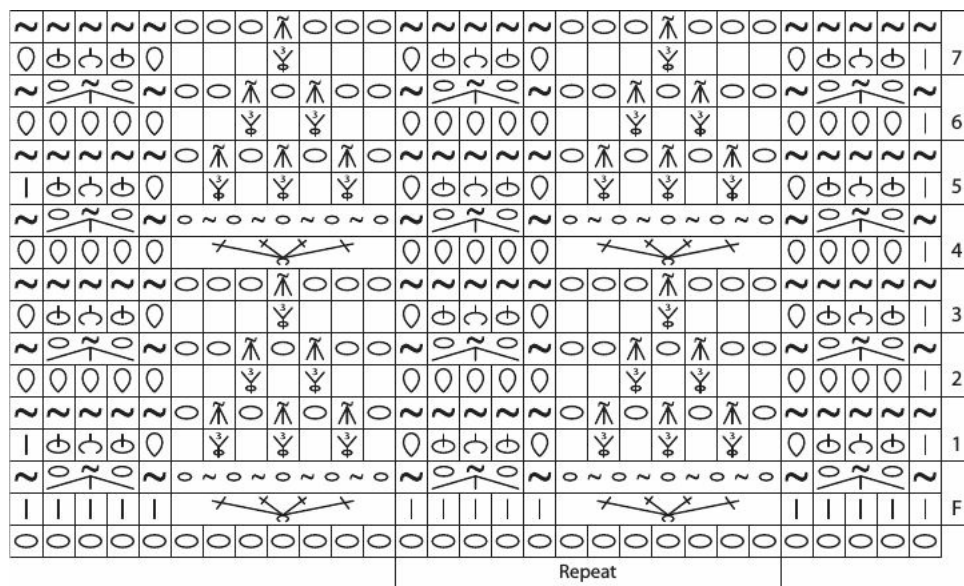





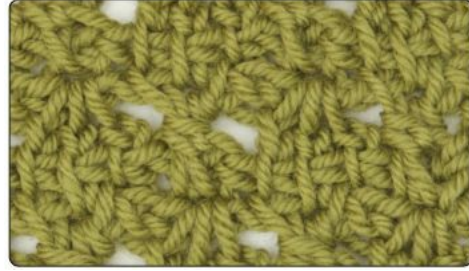







STITCH 61

Chain a multiple of 6 + 5 chs.
Repeat Rows 1-4 for pattern.



KEY

 Chain (ch)	 =  +  +  worked together in top of Closing Cluster
 Tunisian Simple Stitch (tss)	 worked across 3 sts as follows: ch 1 , close 3 sts together, ch 1
 Tunisian Extended Stitch (tes) worked as for tss	 Tunisian Double Crossed Stitch skip next 2 sts, tds in next st, tds in first skipped st (center is unworked)
 Tunisian Full Stitch (tfs)	 Normal Closing
 Tunisian Double Stitch (tds) worked as for tss	

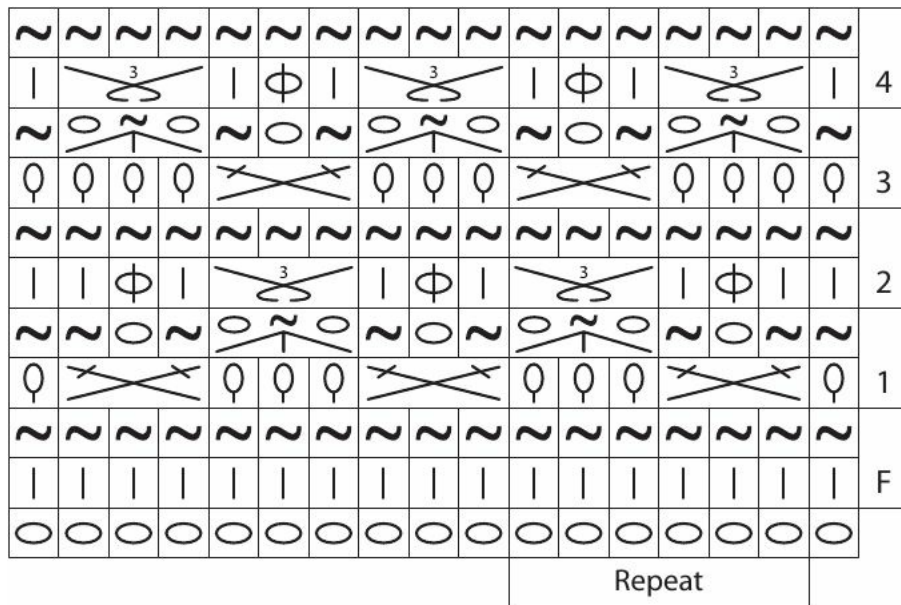

SCARF

■■■■□ INTERMEDIATE

Finished Size: 5½" wide x 59" long (14 cm x 150 cm)

SHOPPING LIST

Yarn (Light Weight)  [3.5 ounces, 307 yards (100 grams, 281 meters) per hank]:

■ One hank

Tunisian Hook

Minimum length of 6" (15 cm)

■ Size L (8 mm) or size needed for gauge

Model was made using Cascade Venezia Sport.

GAUGE INFORMATION

In pattern, 20 sts = 5½" (10 cm); 8 rows = 4" (10 cm)

INSTRUCTIONS

Ch 20.

You can follow the chart on [page](#) or the written instructions.

Foundation Row (Right side): Insert hook in horizontal bar of second ch from hook, YO and pull up a loop, ★ insert hook in horizontal bar of next ch, YO and pull up a loop; repeat from ★ across, close.

Row 1: Skip first vertical bar, ★ insert hook from right to left under each of next 3 vertical bars, YO and pull up a loop, YO, insert hook from right to left under same 3 vertical bars, YO and pull up a loop; repeat from ★ across to last st, tss in last st, close.







Row 2: Skip first vertical bar, work tss across, close.
 Repeat Rows 1 and 2 until Scarf measures approximately 58¾" (149 cm) from beginning ch, ending by working Row 2.

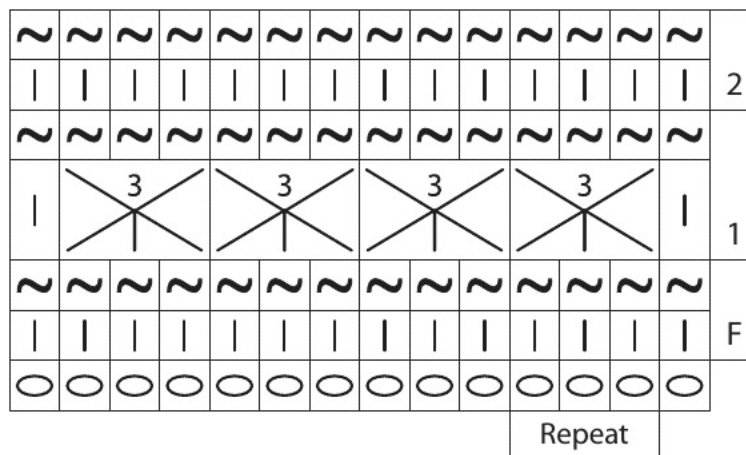

Last Row: Ch 1, skip first vertical bar, working as for tss, sc in each st across; finish off.
 Blocking helps to smooth your work and give it a professional appearance. Follow the yarn label's instructions for laundering before blocking. Pin out your piece to the correct size with rust-proof pins and allow to dry completely.
 Repeat Rows 1-2 for pattern.



KEY

 Chain (ch)

 Tunisian Simple Stitch (tss)

 =  +  Insert hook as for tss in next 3 sts, YO and pull up a loop, YO, insert hook in same 3 sts, YO and pull up a loop (3 loops made)

 Normal Closing

TIP: For a different look, use two yarn colors as shown in [Stitch 40](#) on page 56, the pattern stitch used for this single-color Scarf.

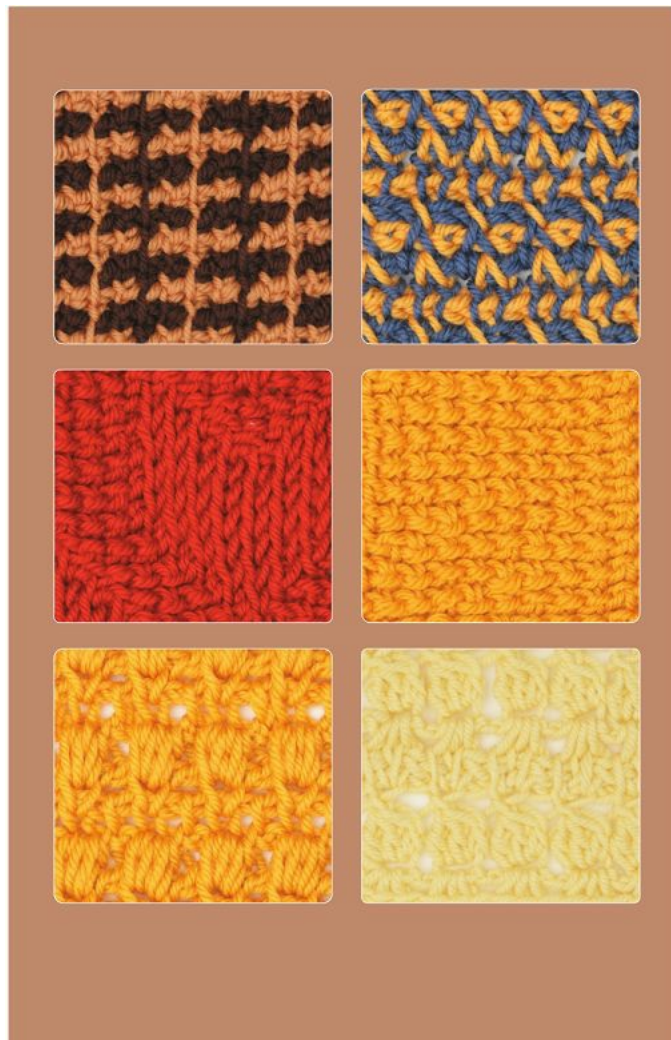

General Instructions

Close-up photos and step-by-step directions for the all-important Foundation Row and the basic stitches of Tunisian Crochet.

This handy reference guide is filled with photos and explanations that you will use again and again as you learn to make the 61 pattern stitches in this book. You'll learn where to work in the starting chain to create the Foundation Row, and you'll have directions for all the basic stitches -- together in one place for your convenience. There also are instructions for decreasing and for changing colors.

ABBREVIATIONS

ch(s)	chain(s)
cm	centimeters
mm	millimeters
tbs	Tunisian Bobble Stitch
tds	Tunisian Double Stitch
tds2tog	Tunisian Double Stitch 2 together
tes	Tunisian Extended Stitch
tfs	Tunisian Full Stitch
tk	Tunisian Knit Stitch
tps	Tunisian Purl Stitch
trs	Tunisian Reverse Stitch
tss	Tunisian Simple Stitch
tss2tog	Tunisian Simple Stitch 2 together
YO	yarn over

see table

see table

see table see table

SYMBOLS & TERMS

★ — work instructions following ★ as many more times as indicated in addition to the first time.

() or [] — work enclosed instructions as many times as specified by the number immediately following or work all enclosed instructions in the stitch or space indicated or contains explanatory remarks.

colon (:) — the number(s) given after a colon at the end of a row denote(s) the number of stitches you should have on that row.

TUNISIAN CROCHET

Each row in Tunisian crochet is a two step process.

The first step (Forward Pass) will pull up loops and leave them on the hook. The second step (Return Pass) will work the loops off the hook until one loop remains. This loop is the first stitch of the next row.

FOUNDATION ROW

Chain the number indicated in the pattern stitch.

Forward Pass: Pull up a loop in horizontal bar of second ch from hook and each ch across (Fig. 1a).

To close (Return Pass): YO and draw through one loop on hook (ch 1 made) (Fig. 1b), (YO and draw through 2 loops on hook) across (Fig. 1c): one loop.



Fig. 1a



Fig. 1b



Fig. 1c

TUNISIAN SIMPLE STITCH (abbreviated tss)

Insert hook from right to left under next vertical bar (Fig. 2), YO and pull up a loop.



Fig. 2

TUNISIAN KNIT STITCH (abbreviated tks)

Insert hook from front to back between front and back vertical bars of next st (Fig. 3), YO and pull up a loop.



Fig. 3

TUNISIAN KNIT STITCH PURLED

With yarn in front of work, insert hook from front to back between front and back vertical bars of next st (Fig. 4), YO and pull up a loop.



Fig. 4

TUNISIAN REVERSE STITCH (abbreviated trs)

With hook at back of work, insert hook from right to left under back of next vertical bar (Fig. 5), YO and pull up a loop.



Fig. 5

TUNISIAN PURL STITCH (abbreviated tps)

With yarn in front of work, insert hook from right to left under next vertical bar (Fig. 6), YO and pull up a loop.



Fig. 6

TUNISIAN TWISTED KNIT STITCH

Using the hook tip, pull the front vertical bar over until you see the back vertical bar (Fig. 7). Insert hook between vertical bars, YO and pull up a loop.

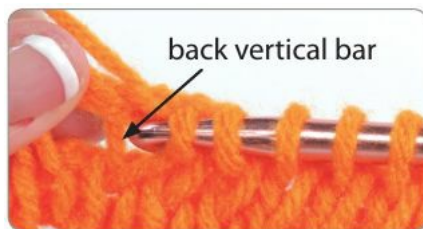

Fig. 7

TUNISIAN TWISTED SIMPLE STITCH

Using the hook tip, grasp the front vertical bar of next st, twist the hook down and around, forming a twist (Fig. 8), YO and pull up a loop.



Fig. 8

TUNISIAN EXTENDED STITCH (abbreviated tes)

Insert hook from front to back between front and back vertical bars of next st, YO and pull up a loop, [YO (Fig. 9) and draw through one loop on hook (chain 1 made)].

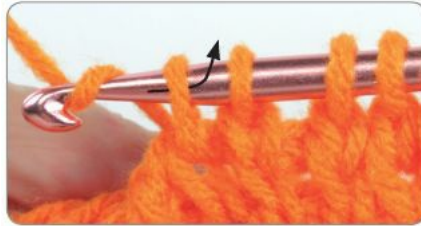

Fig. 9

TUNISIAN DOUBLE STITCH (abbreviated tds)

YO, insert hook from right to left under next vertical bar, YO and pull up a loop, YO and draw through 2 loops on hook (Figs. 10a & b).



Fig. 10a



Fig. 10b

TUNISIAN BOBBLE STITCH (abbreviated tbs)

Work 3 tds in stitch indicated (Fig. 11a), YO and draw through 3 loops (Fig. 11b).



Fig. 11a



Fig. 11b

TUNISIAN CROSSED STITCH (uses 2 sts)

Skip next vertical bar, insert hook from right to left under next vertical bar (Fig. 12a), YO and pull up a loop, insert hook from right to left under skipped vertical bar, YO and pull up a loop (Fig. 12b).



Fig. 12a



Fig. 12b

TUNISIAN DOUBLE CROSSED STITCH

(uses 3 sts) Skip next 2 vertical bars, work tds under next vertical bar (Fig. 13a), work tds under first skipped vertical bar (Fig. 13b).



Fig. 13a



Fig. 13b

TUNISIAN FULL STITCH (abbreviated tfs)

Insert hook from front to back under horizontal bar between two sts (Fig. 14), YO and pull up a loop.

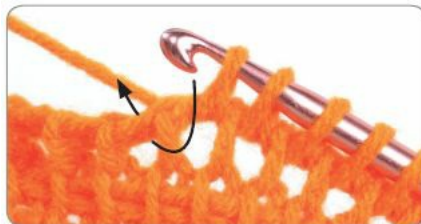

Fig. 14

TUNISIAN SLIP STITCH

Insert hook from right to left under next vertical bar (Fig. 15) and leave loop on hook.



Fig. 15

DECREASES

TUNISIAN DOUBLE STITCH 2 TOGETHER (abbreviated tds2tog)

YO, insert hook from right to left under next 2 vertical bars (Fig. 16), YO and pull up a loop, YO and draw through 2 loops on hook.



Fig. 16

TUNISIAN SIMPLE STITCH 2 TOGETHER (abbreviated tss2tog)

Insert hook from right to left under next 2 vertical bars (Fig. 17a), YO and draw through 2 loops on hook (Fig. 17b).



Fig. 17a



Fig. 17b

CHANGING COLORS

To change colors on a return pass, close across to last 2 sts. Drop the old yarn and with the new yarn (Fig. 18a), yarn over and draw through 2 loops on hook.









Fig. 18a





To change colors on a forward pass, work across all sts. Drop the old yarn, yarn over and pull through one loop (Fig. 18b), then close with the new yarn.



Fig. 18b

Yarn Weight Symbol & Names	LACE 	SUPER FINE 	FINE 	LIGHT 	MEDIUM 	BULKY 	SUPER BULKY 
Type of Yarns in Category	Fingering, 10-count crochet thread	Sock, Fingering Baby	Sport. Baby	DK, Light Worsted	Worsted, Afghan, Aran	Chunky, Craft, Rug	Bulky, Roving
Crochet Gauge* Ranges in Single Crochet to 4" (10 cm)	32-42 double crochets**	21-32 sts	16-20 sts	12-17 sts	11-14 sts	8-11 sts	5-9 sts
Advised Hook Size Range	Steel*** 6,7,8 Regular hook B-1	B-1 to E-4	E-4 to 7	7 to 1-9	to K-10.5	K-10.5 to M-13	M-13 and larger

"GUIDELINES ONLY: The chart above reflects the most commonly used gauges and hook sizes for specific yarn categories.

 BEGINNER	<p>Projects for first-time crocheters using basic stitches. Minimal shaping.</p>
 EASY	<p>Projects using yarn with basic stitches, repetitive stitch patterns, simple color changes, and simple shaping and finishing.</p>
 INTERMEDIATE	<p>Projects using a variety of techniques, such as basic lace patterns or color patterns, mid-level shaping and finishing.</p>
 EXPERIENCED	<p>Projects with intricate stitch patterns, techniques and dimension, such as non-repeating patterns, multi-color techniques, fine threads, small hooks, detailed shaping and refined finishing.</p>

CROCHET HOOKS

U.S.	B-1	C-2	D-3	E-4	F-5	G-6	H-8	I-9	J-10	K-10 ¹ / ₂	L-11	M/N-13
Metric-mm	2.25	2.75	3.25	3.5	3.75	4	5	5.5	6	6.5	8	9

CROCHET TERMINOLOGY

UNITED STATES

slip stitch (slip st)

single crochet (sc)

half double crochet (hdc)

double crochet (dc)

treble crochet (tr)

double treble crochet (dtr)

triple treble crochet (tr tr)

skip

INTERNATIONAL

= single crochet (sc)

= double crochet (dc)

= half treble crochet (htr)

= treble crochet(tr)

= double treble crochet (dtr)

= triple treble crochet (ttr)

= quadruple treble crochet (qtr)

= miss

Table of Contents

TITLE PAGE	2
COPYRIGHT PAGE	3
KIM GUZMAN	5
LEARN MORE ABOUT TUNISIAN CROCHET IN THESE LEISURE ARTS BOOKS!	5
CHAPTER 1 LEARNING CHARTS	8
STITCH 1	11
STITCH 2	12
STITCH 3	13
STITCH 4	14
STITCH 5	14
STITCH 6	15
STITCH 7	16
STITCH 8	18
STITCH 9	19
STITCH 10	20
STITCH 11	21
STITCH 12	22
STITCH 14	24
CHAPTER 2 TYPICAL STITCHES	27
STITCH 15	27
STITCH 16	28
STITCH 17	29
STITCH 18	29
STITCH 19	30
STITCH 20	31
STITCH 21	32
STITCH 22	33
STITCH 23	34
STITCH 24	35
STITCH 25	37
STITCH 26	37
STITCH 27	39
STITCH 28	41
STITCH 29	42
STITCH 30	43
STITCH 31	44
CHAPTER 3 COLOR STITCHES	48
STITCH 32	48
STITCH 33	49
STITCH 34	50
STITCH 35	51
STITCH 36	52
STITCH 37	52
STITCH 38	49

STITCH 39	55
STITCH 40	56
STITCH 41	57
STITCH 42	58
STITCH 43	59
CHAPTER 4 LACE STITCHES	62
STITCH 44	62
STITCH 45	63
STITCH 46	64
STITCH 47	64
STITCH 48	65
STITCH 49	66
STITCH 50	67
STITCH 51	69
STITCH 52	70
STITCH 53	71
STITCH 54	72
STITCH 55	73
STITCH 56	74
STITCH 57	75
STITCH 58	75
STITCH 59	76
STITCH 60	78
STITCH 61	79
SCARF	81
GAUGE INFORMATION	81
INSTRUCTIONS	81
GENERAL INSTRUCTIONS	85